

START EVO

SPIRAL MIXER WITH FIXED BOWL

MIXER
ART OF MIXING

PROFESSIONAL

CAPACITY (kg)

- 35
- 50
- 60
- 80
- 120
- 160



START EVO

SPIRAL MIXER WITH FIXED BOWL

PROFESSIONAL

TECHNICAL FEATURES

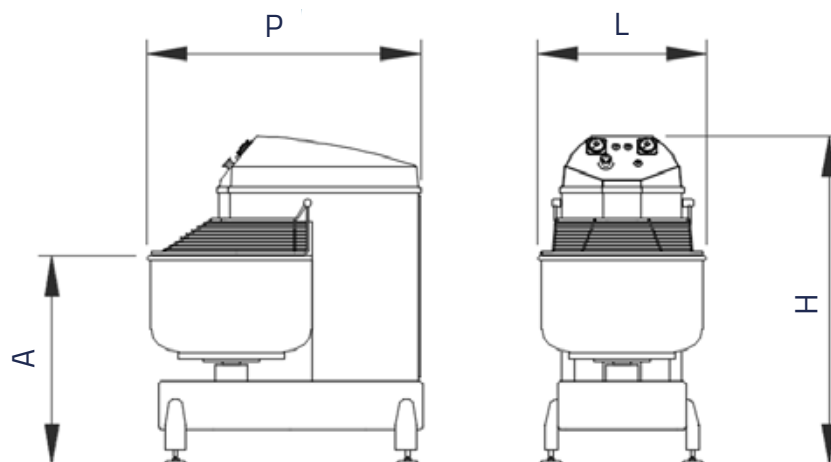

TECHNICAL DATA

MODEL		START 35	START 50	START 60	START 80	START 120	START 160
Dough capacity (min./max) *	kg	8/35	8/50	15/60	15/80	20/120	20/160
Flour capacity (min./max) *	kg	5/22	5/30	9/38	9/50	12/75	12/100
Water capacity (min./max) *	lt	3/13	3/20	6/22	6/30	8/45	8/60
Bowl volume	lt	50	75	100	120	205	240
% water/flour minimum	%	55	55	55	55	55	55
Spiral turns 1st / 2nd speed (50/60Hz)	rpm	95/189	95/189	93/184	93/184	92/183	92/183
Bowl turns 1st / 2nd speed (50/60Hz)	rpm	8.5/17	8.5/17	9/18	9/18	9/18	9/18
Motors power 1st/2nd speed	kw	0.8/1.6	0.8/1.6	1.5/3	1.5/3	3/5.2	3/5.2
Current drawn V 230/400	A	7.2/3.7	7.2/3.7	11.5/6.8	11.5/6.8	19.5/12	19.5/12
Spiral bar diameter	mm	28	28	30	30	40	40
Height from bowl edge	A mm	615	650	780	790	840	900
Total depth	P mm	875	945	1030	1100	1240	1240
Total width	L mm	550	565	645	700	845	845
Height	H mm	1100	1100	1250	1250	1390	1390
Net weight	kg	170	190	255	260	395	400

*: capacity based on the percentage of liquid/flour = 60%

All data are to be considered as nominal, MIXER srl reserves the right to make any changes to the product and/or technical specifications without notice.

STANDARD FEATURES

- Painted steel rack raised from the ground on 4 adjustable feet.
- Bowl, spiral, contrast column and guard made of stainless steel.
- A two-speed motor for spiral and bowl.
- Movement is transmitted by pulleys and V-belts.
- Bowl thrust roller.
- Frontal control with two timers.
- Setting of work time with automatic shift from 1st to 2nd speed.

ON REQUEST

- Machine assembled on wheels (2 fixed rear wheels and 1 pivoting front wheel).
- Stainless steel bowl lid with airtight polyethylene rim.
- Special voltage/frequency: 230/50/3 220/60/3 380/60/3.
- Packaging in wooden crate.