

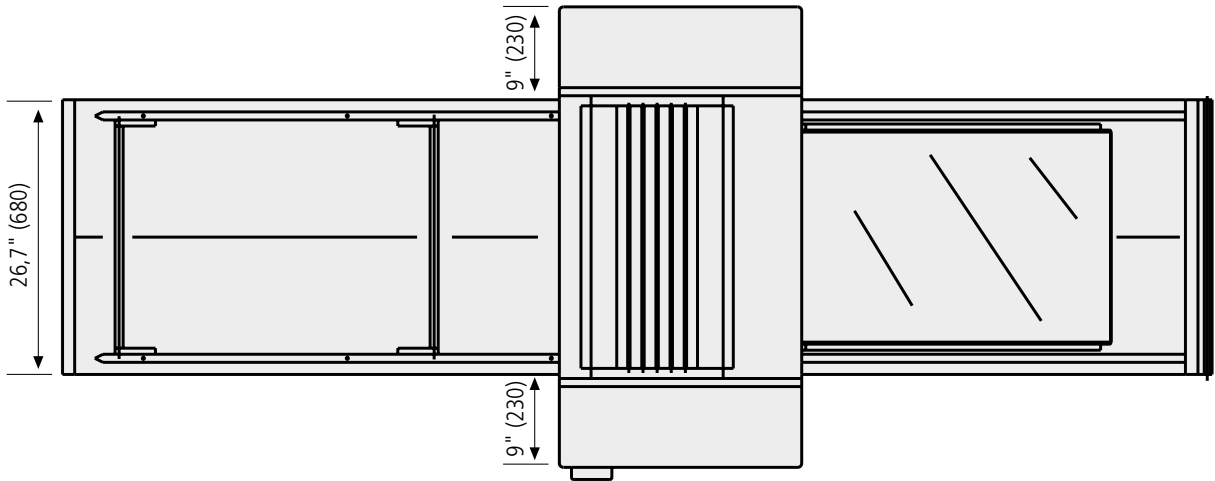

# CLASSIC ROTARY MOULDER

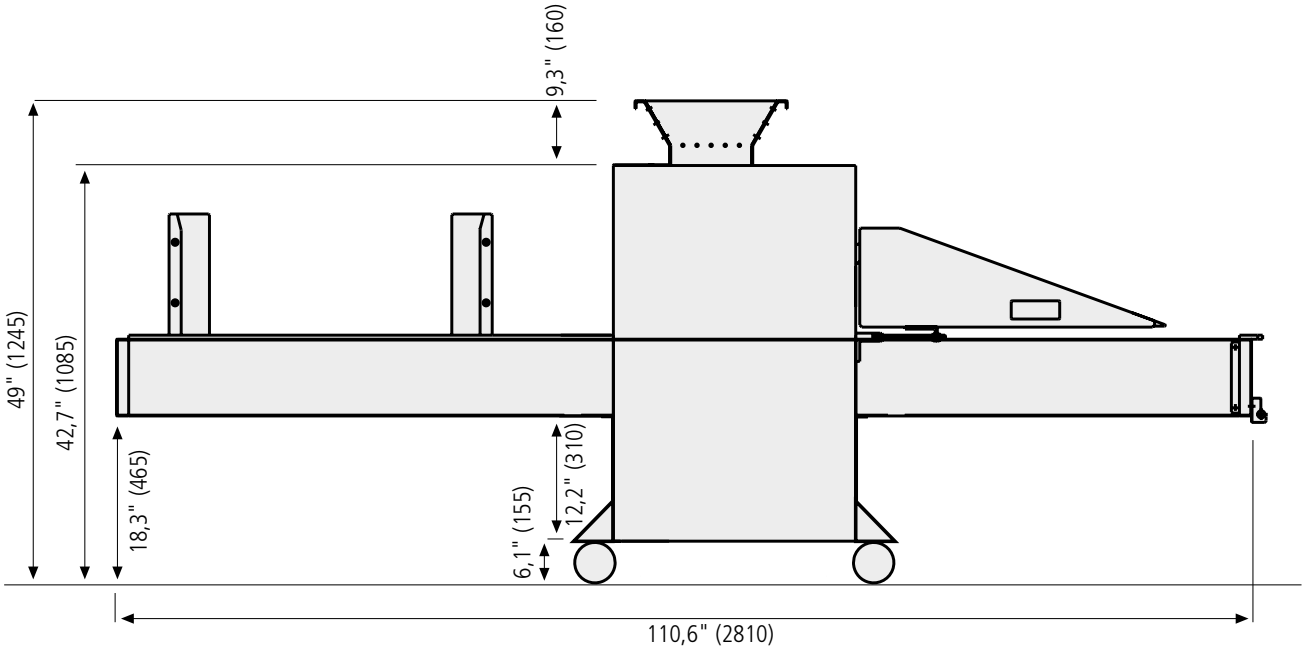

	TRAYS SIZE		HOPPER CAPACITY	TRAYS/HOUR 1ST SPEED	UNBAKED BISCUITS OUTPUT	POWER	WEIGHT
	width	length					
	in (mm)	in (mm)	l	n°	lb/h (Kg/h)	kW	lb (Kg)
RTV 450	14,1÷18,1 (360÷460)	51,2 (1300)	40	420	638 (290)	0,75	1320 (600)